

NOVALIGHT GATEWAY 2G/3G/ETH

NL-G-023NCE

NOVACOM NETWORK GATEWAY AND CABINET CONTROLLER

NovaLight Gateway is a network gateway allowing the connection of luminaire controllers to a centralized software, as well as the control of electrical cabinets by controlling digital outputs or reading digital inputs.

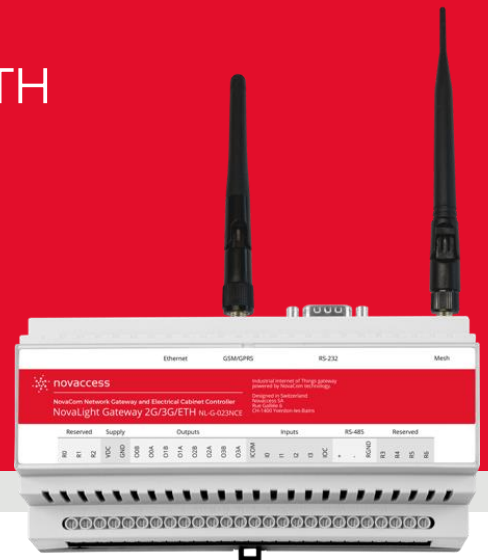

IN A NUTSHELL

The primary role of the NovaLight Gateway is to generate a NovaCom Smart-City wireless network to connect luminaire controllers to the remote management software. The NovaCom network has a mesh topology allowing each object in the network to exchange data with its neighbors and to extend the network coverage. The NovaLight Gateway is mounted on a standard 35mm DIN rail. It is powered by an 230VAC-24VDC power supply available as an option.

In order to guarantee the product's long-term durability and security, the NovaLight Gateway can be reprogrammed directly from the software on the Cloud or locally via configuration software installed on a computer. The NovaLight Gateway can also trigger lighting scenes by activating its digital inputs, for example connected to push buttons.

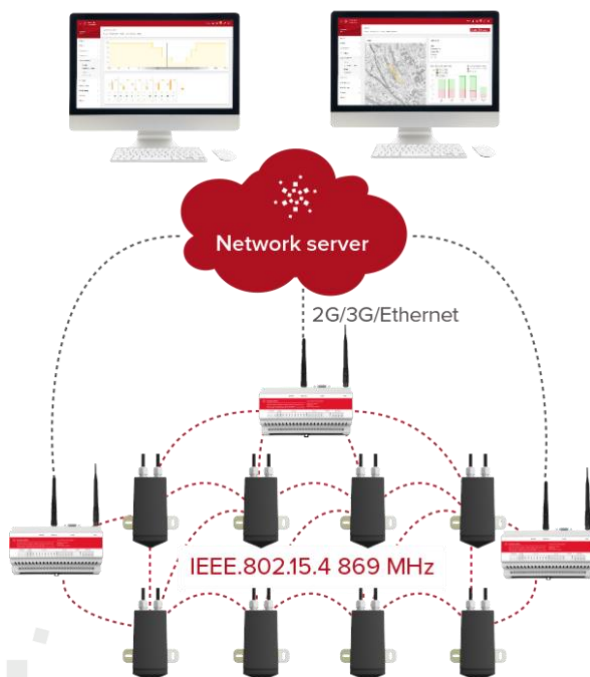

KEY ELEMENTS

- > NovaCom Smart City wireless mesh network gateway, IIoT IEEE 802.15.4 869MHz
- > Supports up to 256 devices in the mesh network, with a recommendation of 128 for optimal performance
- > Robust 3G connectivity with 2G as backup
- > Ethernet connectivity (10/100Mbps IPv4)
- > Local configuration by PC via serial cable
- > Remote control of a control cabinet with 4 digital inputs, 4 relay outputs, RS-232/485 interfaces
- > AES-128 encryption for the mesh network and AES-256 for data and server communication
- > 12/24VDC power supply
- > Remote reprogramming
- > Options for remote antennas

TECHNICAL CHARACTERISTICS

MECHANICAL

PHYSICAL PARAMETERS	VALUE	UNIT
Height	98	[mm]
Width	157	[mm]
Depth	86	[mm]
Weight	250	[gr]

The NovaLight Gateway mounts on a 35mm DIN rail (DIN 43880) with a length of 9 units, approximately 160mm. A 230VAC/24VDC power supply is not included in the standard package but is available as an option if required. The upper part of the box has 4 sockets: a 10/100Mbps Ethernet LAN socket, a SMA antenna port for 3G/2G network, a DB9 female socket for a RS-232 serial configuration cable and a SMA antenna port for the wireless mesh network.

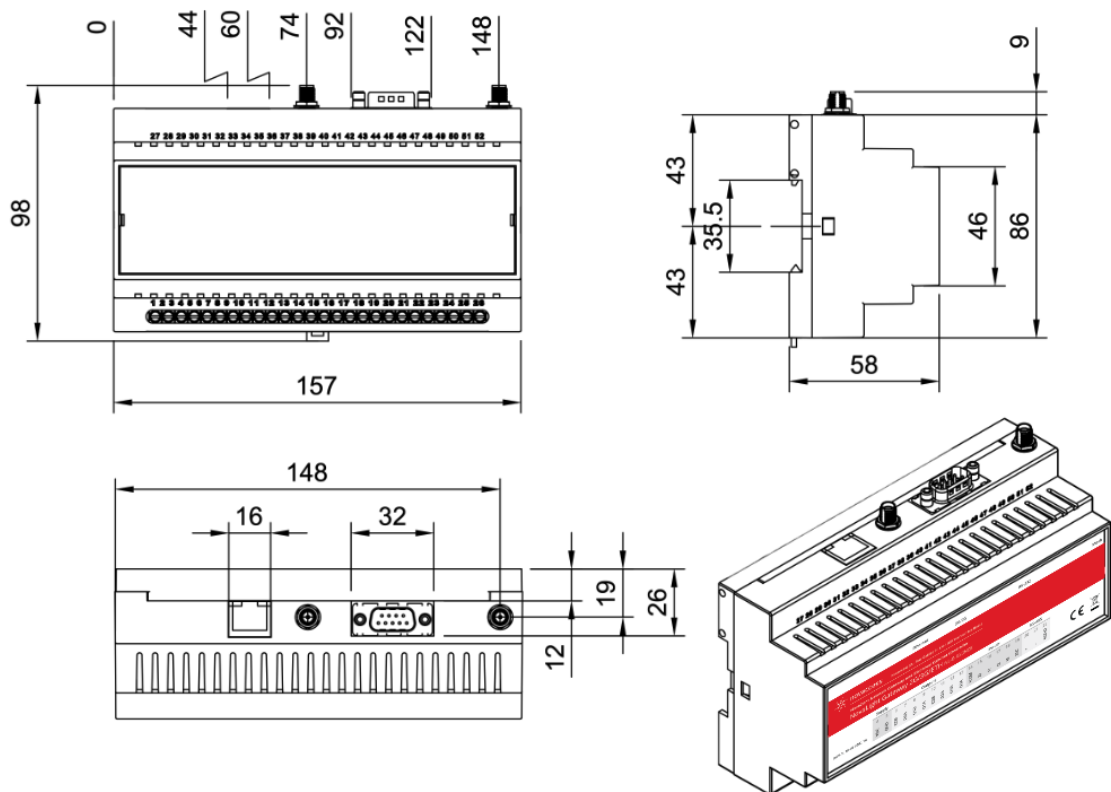

ENVIRONMENTAL PARAMETERS	MIN	TYP.	MAX	UNIT
Operating temperature	-30		+75	[°C]
Humidity in operation	10		90	[%RH]
Protection of the case		IP30		
Shock protection		IK09		

ELECTRICAL

The power supply for the NovaLight Gateway is 24VDC.

ELECTRICAL PARAMETERS	MIN	TYP.	MAX	UNIT
Input voltage	10	24	38	[VDC]
Power consumption	1	1.5	2.5	[W]

WIRING

The minimal wiring of the NovaLight Gateway requires only the installation of the cellular and wireless antennas, and the 24VDC power supply on numbers 4 (24VDC) and 5 (GND). The cellular antenna must also be mounted on the NovaLight Gateway if the Ethernet LAN interface is used. Note that the 230VAC-24VDC power supply is not included with the product as standard, but is available as an option if required.

The antennas must be connected before powering the unit to avoid damage.

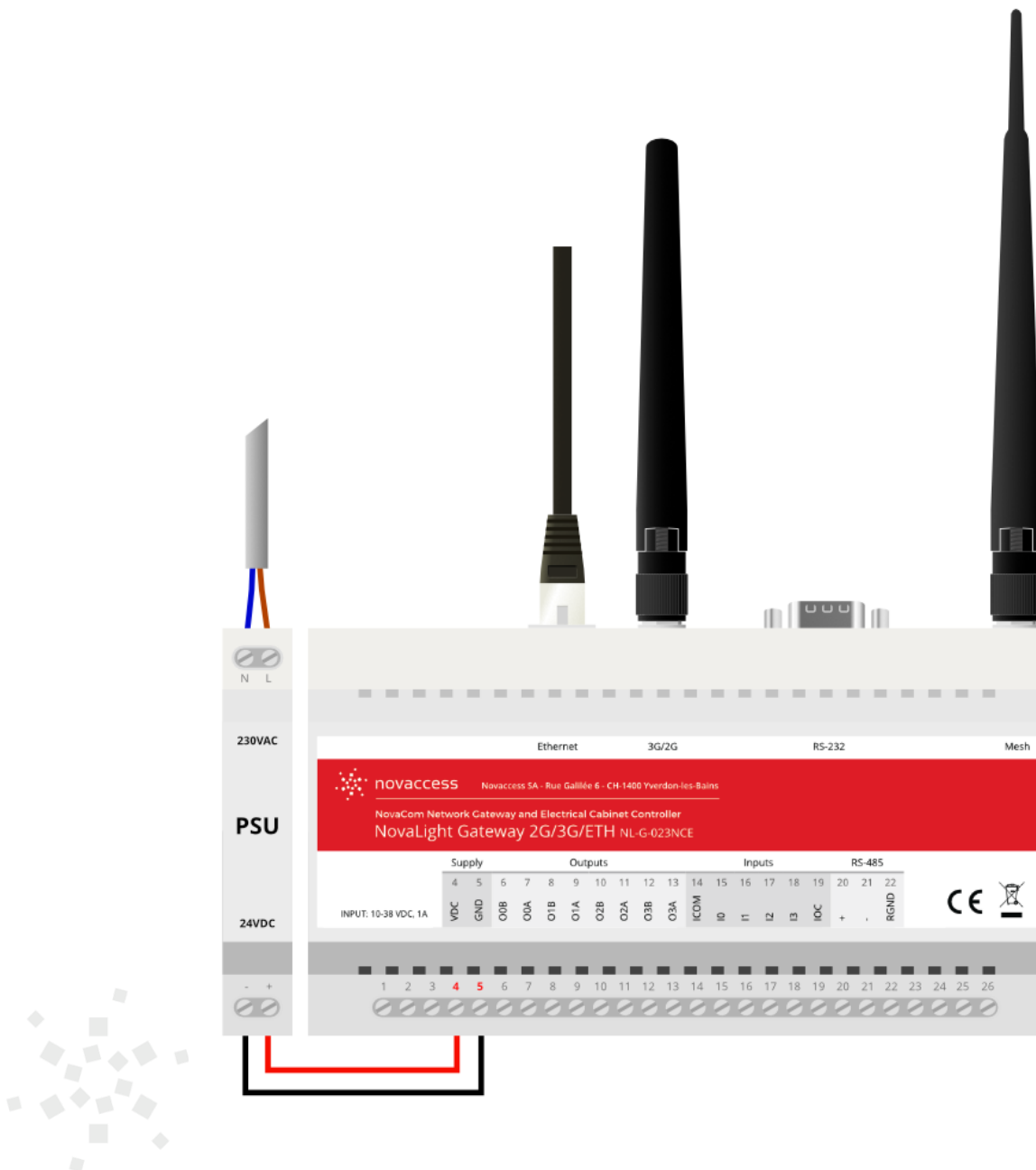

COMMUNICATION

SMART-CITY WIRELESS NETWORK NOVACOM

PARAMETERS	MIN	TYP.	MAX	UNIT
Frequency	-	869.525	-	[MHz]
Bitrate	-	38.4	-	[kbps]
Power	-	100	-	[mW]
Sensitivity	-	-104	-	[dBm]
Range	-	150	600	[m]

This product generates a wireless communication network with a mesh topology, low data rate and low power consumption. This network can be reused for other Smart City applications. A mesh topology means that the communication network initially generated by a NovaLight Gateway can be extended by all devices connected to it (relayed signals). The controllers can also exchange messages directly with each other. This mechanism is notably used for the creation of light paths with dynamic lighting, or volumetric lighting according to the hourly traffic.

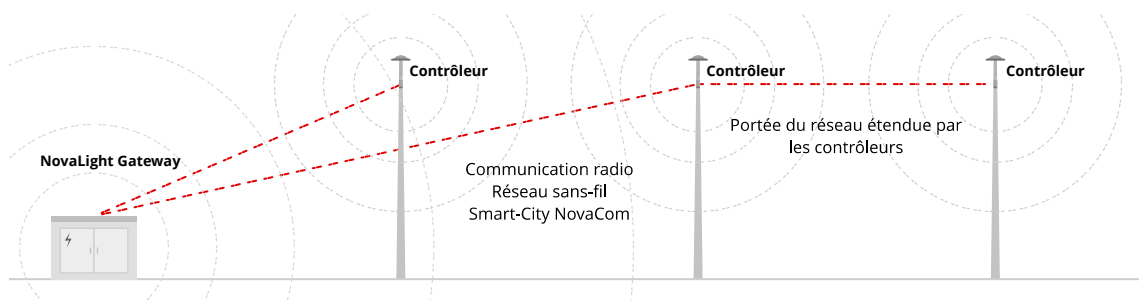

A communication between controllers usually takes place in a few tens of milliseconds. The depth of the network - i.e. the number of intermediate controllers allowing the network to be extended - is limited to 15 hops, which means that a single NovaLight Gateway could cover more than 2.5km with its network for a longitudinal route thanks to the relays.

CONNECTION PROCESS

At startup, the NovaLight Gateway connects to the remote management server, which tells it which wireless network it should generate. The devices in range ask it if they are allowed to connect to its network. It checks with the server to see if the controllers in question are registered and authorized to connect to it. The NovaLight Gateway also relays connection requests from devices already connected to the network that have received requests from new devices in their radio range.

On subsequent start-ups, the connected devices will remember their respective networks and will therefore not restart the connection procedure. They will therefore be immediately accessible via the network, even if their connectivity status has not yet been updated on the remote management platform. It may take several tens of minutes before all the controllers in the network have communicated and updated their connectivity status.



INTERNET NETWORK

The NovaLight Gateway has two network interfaces for connecting to the Internet: 3G/2G cellular or Ethernet LAN. The two interfaces can be configured in parallel, and the NovaLight Gateway will give preference to the interface selected as preferred by the configuration software. The management platform allows you to monitor the use of each of these interfaces.



CELLULAR NETWORK

The NovaLight Gateway has a 3G/2G cellular interface that requires a SIM card to operate. The SIM card holder is located inside the box. The configuration of the SIM card is done using the Novaccess Device Center software available from our technical support. The interface automatically chooses the best available technology for the connection, 3G if possible and 2G if not. Different parameters are required: an APN with an optional username and password and a PIN code. The platform automatically recognizes the name of the network operator, the quality of the cellular signal, the technology used, the IMEI and IMSI number.

The cellular antenna must be connected to the port between the Ethernet socket and the DB9 serial connector before powering the unit to avoid damage.

PARAMETERS	VALUES
Technology	3G HSPA : B1/B8 2G GSM/GPRS : 900/1800 MHz (UTRA naming convention)
Zones	Europe
Output	Coaxial SMA femelle
SIM card holder	MINI SIM (compatible with micro and nano SIM)

LAN NETWORK

The NovaLight Gateway's Ethernet LAN interface is configured by default to operate in DHCP on an IPv4 network. The interface can be configured as a static address if required, or can be connected to a VLAN interface. It is possible to query the device via an ICMP request (Ping) to check its availability via the network. This option can be disabled if required.

PARAMETERS	VALUES
Connector	RJ-45
Speed	10/100Mbps
Protocol	IPv4



INPUTS/OUTPUTS



DIGITAL INPUTS

The NovaLight Gateway's inputs can be connected in two ways: dry contact mode and push-pull mode. All digital inputs are materially identical.

PARAMETERS	MIN	TYP.	MAX	UNIT
Input current 0 to 3	-	-	3	[mA]
Input voltage 0 to 3	10	12	24	[VDC]

Different functions can be assigned to the digital inputs: electrical status monitoring, light scene, traffic counter. The monitoring of an electrical status allows to know if an electrical segment is active or not. The light scene allows to define a light intensity level on a group of luminaire controllers for a certain period of time. The traffic counter function allows the connection of a device that closes a dry contact when a vehicle passes by, in order to realize a dimming according to the traffic volume. All connections to the digital inputs must not exceed 3 meters in length.

The following illustration is taken from the remote control software, from which scenes can also be triggered. The luminaire groups and scenes/rules are configured in the remote control software.

Nom	Déclencheur	Action	
Éteint	Changement d'intensité multicast - in0	Activation d'entrée - 0%	  
Manifestation	Changement d'intensité multicast - in1	Activation d'entrée - 10%	  
Entrainement	Changement d'intensité multicast - in2	Activation d'entrée - 70%	  
Match	Changement d'intensité multicast - in3	Activation d'entrée - 100%	  

DRY CONTACT MODE

In the dry contact mode, the 24VDC voltage (high logic level) is taken from terminal number 14 (ICOM) of the NovaLight Gateway, and connected to the dry contact of the system to be monitored. The output of the dry contact can then be connected to one of the four inputs (I0 to I3).

Example of wiring with independent push buttons (preferred)

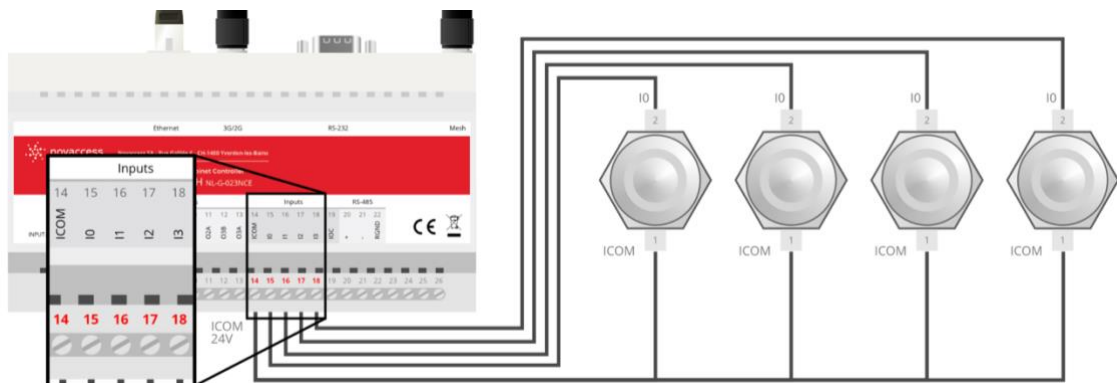

Example of wiring with a 4-position rotary switch.

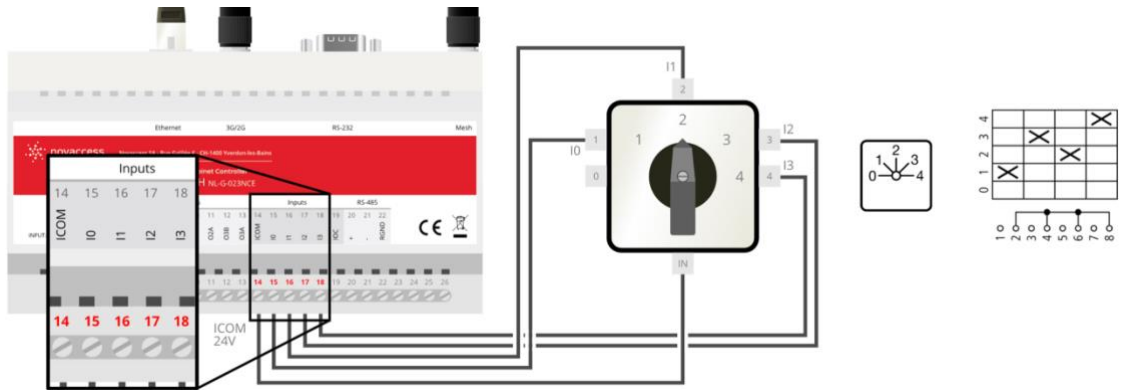

PUSH-PULL MODE

In push-pull mode, the high logic level is given by the third-party system and the common potential is connected between the NovaLight Gateway and the third-party system. The common potential must be the same for all inputs. The third-party system then concurrently controls the high and low logic level given to the NovaLight Gateway.

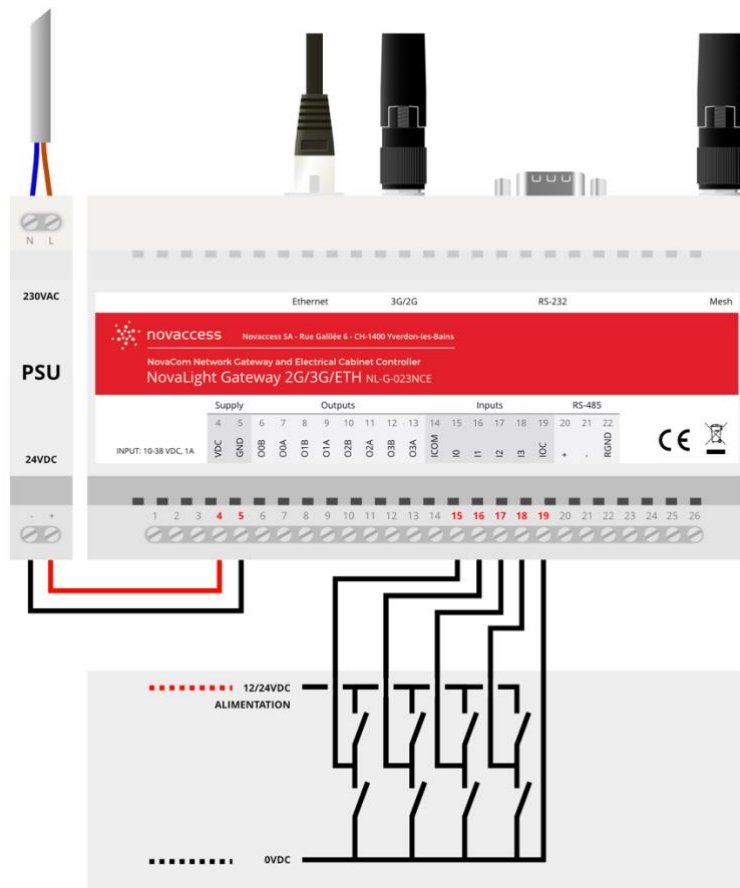

OUTPUT CONTACTS

The NovaLight Gateway has 4 output contacts. All contacts are Normally Open (NO) by default. Contact 0 is controlled by a mechanical relay and contacts 1 to 3 are controlled by optocouplers.

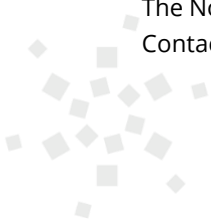

CONTACT 0

The output contact number 0 is controlled by a mechanical relay. This relay allows to control a higher power than the contacts 1 to 3. The 0 contact is available on the blocks positions 7 (O0A, start to equipment) and 6 (O0B, return from equipment).

PARAMETERS	MIN	TYP.	MAX	UNIT
Output current	-	-	4	[A]
Output voltage	-	-	250 30	[VAC] [VDC]
Throughput power			1000	[W]
Type	NO Normally Open			
Charge type	Resistive*			

* A relay coil can be driven with adequate overvoltage protection.

CONTACTS 1-3

Contact output number 1 is divided between block position 9 (O1A, outgoing to equipment) and position 8 (O1B, return from equipment). Contact output number 2 is divided between block position 11 (O2A, outgoing) and position 10 (O2B, return). The contact output number 3 starts from block position 13 (O3A) with a return from the equipment in position 12 (O3B).

PARAMETERS	MIN	TYP.	MAX	UNIT
Output current	-	-	0.5	[A]
Output voltage	-	-	24	[VDC]
Type	NO Normally Open			
Charge type	Resistive only			

The outputs are controlled from the remote management software by switching on/off a selector switch and a backup that will initiate the sending of the command to the device. The command is usually applied within a few seconds. The outputs are presented in the station page, and activated from the page of a Novalight Gateway.

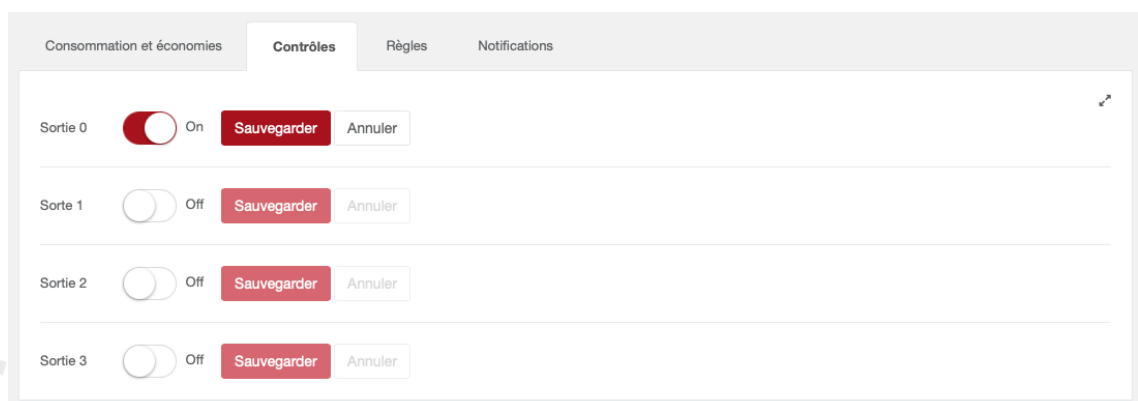

SERIAL INTERFACES

PORT 1 RS-232

This port is connected to the DB9 connector of the NovaLight Gateway box and allows the device to be configured via a computer and the Novaccess Device Center software. The interface operates asynchronously in 115200/8N1 mode.

PARAMETERS	VALUES	UNIT
Interface	RS-232	
Baudrate	115'200	[Bauds]
Data width	8	[bits]
Parity	No	
Stop bit	1	[bit]
Signaling	No	

PORT 2 RS-485

Port 2 is located on the NovaLight Gateway terminal blocks and provides a half-duplex RS-485 interface with a built-in 120 ohm bus load. This interface is used in some cases to connect third-party systems to the NovaLight infrastructure.

The following signals must be connected to operate this interface:

- Position 20 : RS-485 +/P signal
- Position 21 : RS-485 -/N signal
- Position 22 : RGND signal

COMMISSIONING

The commissioning of this product requires access to the remote management software or to the NovaLight mobile application, available for iOS and Android. In order for this product to connect to the remote management platform, it must first be registered. Once connected to the software, the NovaLight Gateway will generate the Smart City NovaCom wireless mesh network.





Application « novalightapp »



Application « novalight »



GENERAL INFORMATION

PRODUCTS REFERENCES

PRODUCTS	REFERENCES
NovaLight Gateway 3G/ETH	NL-G-023NCE
Indoor Mesh antenna	MA-020
Outdoor Dome Mesh antenna	MDDA-020
Outdoor Mural Mesh antenna	MDWA-020
Indoor Cellular antenna	CA-030
Outdoor Dome Cellular antenna	CDDA-020
Outdoor Mural Cellular antenna	CDWA-020
Power supply 230VAC/24VDC DIN	HDR-15-24
USB-Series configuration cable	U209-000-R

PACKAGE CONTENTS

The NovaLight Gateway comes with an indoor mesh antenna and an indoor cellular antenna.

CONFORMITY

Mark	CE (RED)
EMC	EN 301 489-3
SRD	EN 300 220-1/-2
Security	EN 60950-1
Cellular	EN 301 511, EN 301 908-1/2

CHANGE LOG

REVISION	DATE	DESCRIPTION
R01	July, 18 2022	Initial publication

CONDITIONS

All rights reserved. Documents and photographs are not contractual. Novaccess reserves the right to change specifications at any time without notice or obligation and shall not be liable for any consequences resulting from the use of this publication.

